

MODEL	POWER		OUTLET (inch)	MAX.FLOW (L/MIN)	MAX.HEAD (M)	G.W. (Kg)	DIMENSIONS. (mm)
	kw	Hp					
V250A-F	0.25	0.4	1",1.2"	75	8	10.5	440 x 160 x 205
V370A-F	0.37	0.5	1",1.2"	80	9	11	460 x 160 x 205
V550A-F	0.55	0.75	2"	240	10	16.5	445 x 185 x 240
V750A-F	0.75	1.0	2"	250	12	17.94	460 x 185 x 240
V1100A-F	1.1	1.5	2"	310	13	21.65	495 x 195 x 280
V1500A-F	1.5	2.0	2"	420	16	21.8	515 x 195 x 280

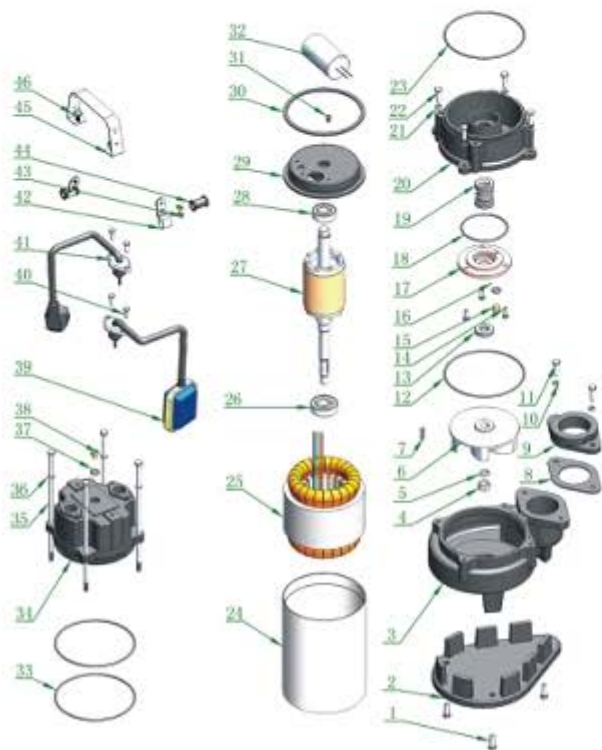

No.	Description	No.	Description	No.	Description
1	Screw	18	O-ring	35	Hexagon screw
2	Pump foot	19	Mechanical seal	36	Washer
3	Pump base	20	Oil chamber	37	O-ring
4	Impeller nut	21	Plain washer	38	Screw
5	Plain washer	22	Screw	39	Float switch
6	Impeller	23	O-ring	40	Screw
7	Key	24	Pump body	41	Sheath
8	Flange washer	25	Stator	42	Cable sheath
9	Flange	26	Bearing	43	Screw
10	Plain washer	27	Rotor	44	Rubber sheath
11	Screw	28	Bearing	45	Handle
12	O-ring	29	Upper lid	46	Screw
13	Oil seal	30	Rubber washer	47	
14	Screw	31	Screw	48	
15	Screw	32	Capacitor	49	
16	Washer	33	O-ring	50	
17	Oil chamber cover	34	Upper cover	51	